

Inset Runway Threshold/End Light

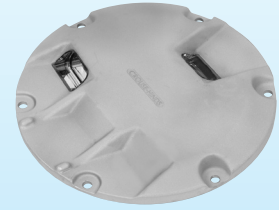

IRTEL

Compliances: FAA AC 150/5345-46: L-850D

Applications

The IRTEL is a medium intensity bidirectional light (using one 48 W lamp for the green side and one 105 watt lamp for the red side). This fixture is used on runways where the threshold and end lighting are co-located and where it is impractical to use an elevated light.

Features

- ETL Certified 
- Low profile, < .50" (12mm) – FAA Style 2
- Low power consumption
- Few parts to stock
- Easy to maintain – no sealant required for prism replacement
- Pressure test plug for seal integrity verification
- Long lamp life – Quartz Halogen, 48 W, 6.6 A
Quartz Halogen, 105 W, 6.6 A
- High-strength forged aluminum

Ordering Information



Fixture Type:

Color*:

- RG = Red/Green
- GR = Green/Red
- GX = Green/Blank
- XG = Blank/Green
- RR = Red/Red

L-823 Plug Connection:

- P1 = One plug
- P2 = Two plugs (Two color units only. Blank is not considered a color.)

* Refer to the color symbol position: the red beam is always straight.
RG means right toe-in of the green beam.
GR means left toe-in of the green beam.
GX means right toe-in of the green beam.
XG means left toe-in of the green beam.

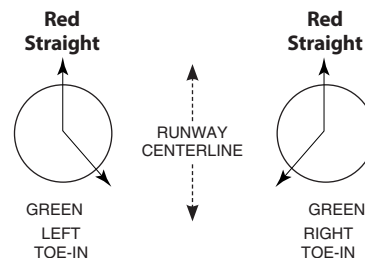

Outline Drawing

Dimensions:	inches (mm)
Instruction Manual:	2811
Shipping Weight:	17.0 lbs 7.7 kg
Shipping Volume:	0.6 cu ft 0.04 m ³

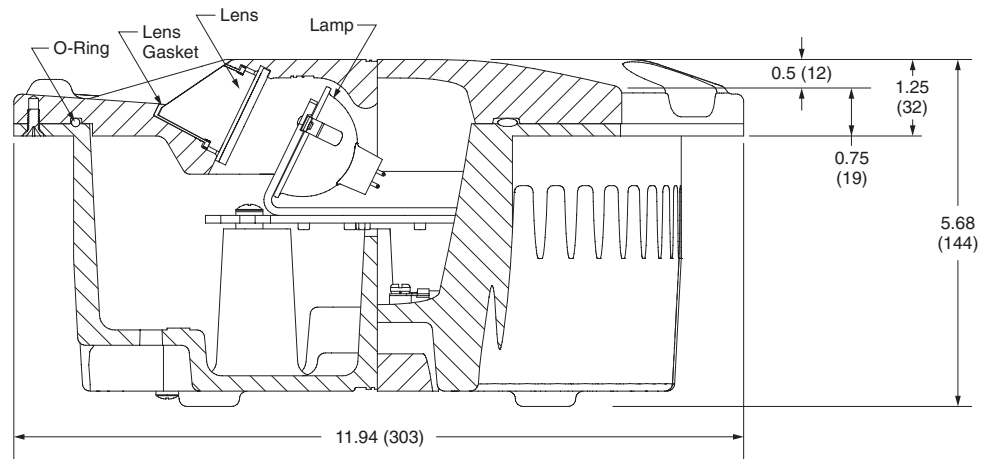

Typical Photometric Data

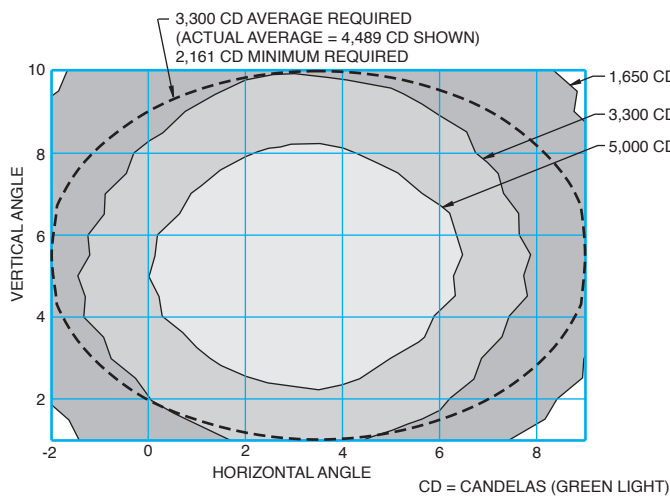

L-850D Inset Runway Threshold/End Light – Green

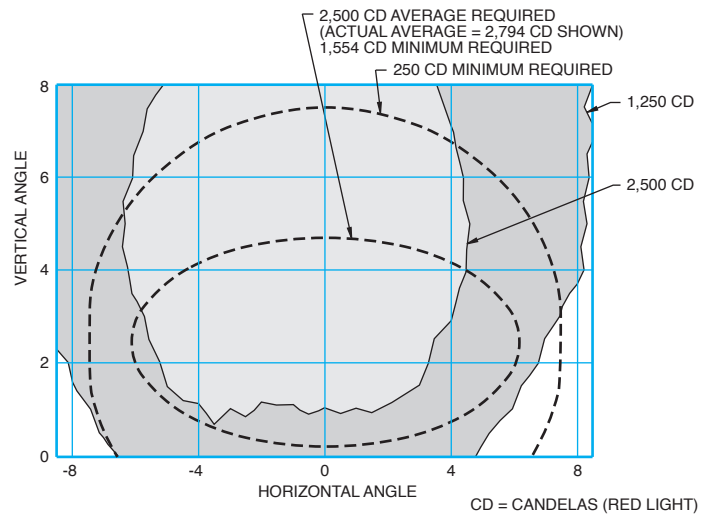

L-850D Inset Runway Threshold/End Light – Red

Accessories

Catalog Number	Item Description	Catalog Number	Item Description
AC24242Q200303	Base: L-868B, Class I, 24" Deep*	823KP-D4-D4	Connector Kit – L-823, 8 AWG, .32" to .43" O.D.
33004	Isolation Transformer – 100 W, 6.6/6.6 A	10047-2154	Heat Shrink Kit – 1 Piece
33005	Isolation Transformer – 100 W, 20/6.6 A	10047-1425	Heat Shrink Kit – 2 Piece
33006	Isolation Transformer – 200 W, 6.6/6.6 A	19999	Lifting Tool
33007	Isolation Transformer – 200 W, 20/6.6 A		

Renewal Parts

Part Number	Description	Part Number	Description
21474	Lamp – 48 W, 6.6 A	10035-33-273	O-Ring – Bottom Cover
21128	Lamp – 105 W, 6.6 A	10048-25	Gasket Lubricant – 5.3 oz. Container
21480-G	Lens Replacement Kit – Green ¹		
21480-R	Lens Replacement Kit – Red ¹		

* Fixture with total lamp wattage greater than 150 W should not be mounted on 12" diameter base less than 20" deep.
Class II bases are not recommended for this application.

Note:

1. Lens Replacement Kit includes lens, lens boot, lens retaining gasket, gasket lubricant, and lens retaining bracket and screws.

