

DOCUMENT 2108
REVISION D
March 2, 2010

COOPER Crouse-Hinds

Instruction Manual



Style 3

12 Inch Taxiway Centerline Light (TCL)

ICAO ANNEX 14, Third Edition,

Figures 2.12, 2.13, 2.14, 2.15, 2.16

Part Number series 852XX3-XX-PX-X

Cooper Industries
Crouse-Hinds Division
Crouse-Hinds Airport
Lighting
1200 Kennedy Road
Windsor, CT 06095

Copyright © 2010 Cooper Technologies Company

For parts and technical service call (860) 683-4300

Instruction Manual
Style 3
12 Inch ICAO Taxiway Centerline Light**1 Revisions**

Revision Number	Issue/Reissue Letter Number	Description	Checked	Approved
A	203-284	INITIAL ISSUE	KWF	JMM
B	A204-146	Para 6.1, red stopbar applications was one 62-watt; Para 6.2 added red stopbar info; Para 6.3 removed red stopbar using 105 watt lamp. Para 10, Item 10, 21169 for 852W33 was qty 1, 21128 for 852W33 was qty 0	6/21/04	GFR
C	A209-101	Parts List, Item 9 was 21115 & 304 Stn Stl was 18-8; FAA AC 150/5345-46D was 46C (all locations)	7/15/09	JRC
D	A210-027	Parts List, Item 21 was 21178;& deleted item 12, P/N 10033-94 and added qty's to item 19; Figure 6, added note with regards to 852NN lamp orientation; Title Page, copyright was 2009	3/2/10	PG

Instruction Manual
Style 3
12 Inch ICAO Taxiway Centerline Light**2 Limited Product Warranty**

THE FOLLOWING WARRANTY IS EXCLUSIVE AND IN LIEU OF ALL OTHER WARRANTIES, WHETHER EXPRESS, IMPLIED OR STATUTORY, INCLUDING, BUT NOT BY WAY OF LIMITATION, ANY WARRANTY OF MERCHANTABILITY OR FITNESS FOR ANY PARTICULAR PURPOSE.

Crouse-Hinds Airport Lighting Products (“the Company”) warrants to each original Buyer of Products manufactured by the Company that such Products are, at the time of delivery to the Buyer, free of material and workmanship defects, provided that no warranty is made with respect to:

- (a) any Product which has been repaired or altered in such a way, in Company’s judgment, as to affect the Product adversely;
- (b) any Product which has, in Company’s judgment, been subject to negligence, accident or improper storage;
- (c) any Product which has not been operated and maintained in accordance with normal practice and in conformity with recommendations and published specification of Company; and,
- (d) any Products, component parts or accessories manufactured by others but supplied by Company (any claims should be submitted directly to the manufacturer thereof).

Crouse-Hinds Airport Lighting Products’ obligation under this warranty is limited to use of reasonable means to repair or, at its option; replace, during normal business hours, at any authorized service facility of Company, any Products which in its judgment proved not to be as warranted within the applicable warranty period. All costs of transportation of Products claimed not to be as warranted and of repaired or replacement Products to or from such service facility shall be borne by Purchaser. Company may require the return of any Product claimed not to be as warranted to one of its facilities as designed by Company, transportation prepaid by Purchaser, to establish a claim under this warranty. The cost of labor for installing a repaired or replacement product shall be borne by Purchaser. Replacement parts provided under the terms of this warranty are warranted for the remainder of the warranty period of the Products upon which they are installed to the same extent as if such parts were original components thereof. Warranty services provided under the Agreement do not assure uninterrupted operations of Products; Company does not assume any liability for damages caused by any delays involving warranty service. The warranty period for the Products is 24 months from date of shipment or 12 months from date of first use whichever occurs first.

Instruction Manual
Style 3
12 Inch ICAO Taxiway Centerline Light

3 Safety Notices lamp

This equipment is normally used or connected to circuits that may employ voltages that are dangerous and may be fatal if accidentally contacted by operating or maintenance personnel. Extreme caution should be exercised when working with this equipment. While practical safety precautions have been incorporated in this equipment, the following rules must be strictly observed:

3.1 KEEP AWAY FROM LIVE CIRCUITS

Operating and maintenance personnel must at all times observe all safety regulations. Do not perform maintenance on internal components or re-lamp with power ON.

3.2 RESUSCITATION

Maintenance personnel should familiarize themselves with the technique for resuscitation found in widely published manuals of first aid instructions.



See FAA Advisory Circular AC 150/5340-26 for additional information.

Instruction Manual
Style 3
12 Inch ICAO Taxiway Centerline Light

4 Table of Contents

Title Page..... i
1.0 Revisions ii
2.0 Limited Product Warranty iii
3.0 Safety Notices iv
4.0 Table of Contents v
5.0 Part Number Explanation – 12-Inch ICAO Taxiway Centerline Light..... 1
6.0 General Description..... 2
 6.1 Taxiway Centerline Light, Figure 2.12..... 2
 6.2 Taxiway Centerline Light, Figure 2.13..... 2
 6.3 Taxiway Centerline Light, Figure 2.14..... 2
 6.4 Taxiway Centerline Light, Figure 2.15..... 2
 6.5 Taxiway Centerline Light, Figure 2.16..... 3
7.0 Installation..... 3
8.0 Maintenance 3
 8.1 Cleaning Lenses..... 3
 8.2 Relamping..... 4
 8.3 Gasket Replacement 4
 8.4 Lens Replacement 5
 8.5 Feed-thru Replacement 5
 8.6 Wedge Filter Replacement..... 5
 8.7 Pressure Test 6
 8.8 Cleanliness and Workmanship 6
 8.9 Maintenance Program 6
9.0 Parts List 9
Figure 1 - 19999 Installation (Lifting)Tool..... 8
Figure 2 - Top View of Fixture 10
Figure 3 - Side View of Fixture 10
Figure 4 - Bottom View of Fixture 11
Figure 5 - Inner Cover Lamp Bracket Positioning 11
Figure 6 - Cut-away View of Fixture 12

Instruction Manual
Style 3
12 Inch ICAO Taxiway Centerline Light

5 Part Number Explanation – ICAO Taxiway Centerline Light

852 3 - - -

FIXTURE TYPE:

- C2 = CURVED SECTIONS, CAT II, FIGURE 2.16
- C3 = CURVED SECTIONS, CAT III, FIGURE 2.14
- N3 = NARROW BEAM, CAT III, FIGURE 2.13
- W2 = WIDE BEAM, CAT II, FIGURE 2.15
- W3 = WIDE BEAM, CAT III, FIGURE 2.12

COLOR FILTERS*:

- YX = YELLOW /BLANK, XY = BLANK / YELLOW
- GX = GREEN/BLANK, XG = BLANK / GREEN
- GY= GREEN/YELLOW, YG = YELLOW / GREEN
- RX= RED/BLANK, XR = BLANK / RED
- GG = GREEN/GREEN
- YY= YELLOW/YELLOW

L-823 CONNECTION:

- P1 = ONE PLUG (BLANK COLOR UNITS WILL HAVE A THREADED PLUG INSTALLED ON SIDE "B" FEED-THRU ADAPTER)
- P2 = TWO PLUGS (TWO COLOR UNITS ONLY , FOR THIS FEATURE ONLY, BLANK IS NOT CONSIDERED A COLOR)

OPTIONS:

- I = 48 W LAMP, P/N 21116, IN PLACE OF STANDARD 32 W LAMP: (GREEN AND YELLOW APPLICATIONS ONLY)

* FOR FIXTURE TYPES C2 AND C3 ONLY: REFER TO THE COLOR SYMBOL POSITION, THE FIRST COLOR IS LEFT TOE-IN, THE SECOND COLOR IS RIGHT TOE-IN.

Instruction Manual
Style 3
12 Inch ICAO Taxiway Centerline Light**6 General Description****6.1 Taxiway Centerline Light, Figure 2.12**

The Crouse-Hinds Figure 2.12 ICAO Taxiway Centerline Light is a Category III wide section inset taxiway light fixture designed to meet the requirements of Appendix 2 of Annex 14, Third Edition. It is installed at the centerline of taxiways or any other location where visual guidance of moving aircraft or ground vehicles is desirable. The fixture is designed to fit on a FAA L-868, steel, Size B light base per FAA AC 150/5345-42 (latest version), and have a total height above grade/ground level of < .250 inch. The operating temperature range is -55°C to +55°C. The power requirement for all versions is 6.6 amperes, from a constant current regulator. The fixture is bi-directional, projecting two beams of light 180° apart. It is weatherproof and will endure roll over loads without damage. The light fixture consists of an aluminum optical assembly and a die cast bottom housing. The bottom housing is attached to the optical housing using six screws. There is an integrated gasket that is bonded to the bottom cover to prevent water from entering the assembled fixture. The fixture is mounted to a light base with six bolts (3/8-16 UNC x 7/8 lg., stn. stl.) and lock washers (3/8, stn. Stl.). Two 32-watt, MR-16 lamps are secured to two brackets, which are fastened to the bottom housing. For red stopbar applications, one 105-watt MR-16 lamp is used. Electrical connections are made at either one or two feed-thru assemblies in the inner cover. The feed-thrus have ITS verified L-823 plugs for connecting to FAA L-830/ L-831 Isolation Transformers. Lenses are held into the aluminum housing with a bracket, gasket, molded elastomeric boot and two screws. There is a wedge shaped glass filter with fresnel lensing mounted to the optical housing between each lamp and lens. The light beam color is changed when it passes through the wedge, which can be changed in the field.. All hardware is type 18-8 stainless steel. The complete light unit is 11.94 inches in diameter, 3.63 inches deep, and weighs 12 lbs.

6.2 Taxiway Centerline Light, Figure 2.13

The Crouse-Hinds Figure 2.13 ICAO Taxiway Centerline Light is a Category III narrow section inset taxiway light fixture designed to meet the requirements of Appendix 2 of Annex 14, Third Edition. Its design is identical to the Figure 2.12 fixture described in section 6.1 except red stopbar applications use a 62 watt MR-16 lamp.

6.3 Taxiway Centerline Light, Figure 2.14

The Crouse-Hinds Figure 2.14 ICAO Taxiway Centerline Light is a Category III curved section inset taxiway light fixture designed to meet the requirements of Appendix 2 of Annex 14, Third Edition. Its design is identical to the Figure 2.12 fixture described in section 6.1 except the light pockets in the optical housing are offset 15.75 degrees horizontal.

6.4 Taxiway Centerline Light, Figure 2.15

The Crouse-Hinds Figure 2.15 ICAO Taxiway Centerline Light is a Category II wide section inset taxiway light fixture designed to meet the requirements of Appendix 2 of Annex 14, Third Edition. Its design is identical to the Figure 2.12 fixture described in section 6.1, except red stopbar applications use a 32watt MR-16 lamp.

Instruction Manual
Style 3
12 Inch ICAO Taxiway Centerline Light**6.5 Taxiway Centerline Light, Figure 2.16**

The Crouse-Hinds Figure 2.14 ICAO Taxiway Centerline Light is a Category II curved section inset taxiway light fixture designed to meet the requirements of Appendix 2 of Annex 14, Third Edition. Its design is identical to the Figure 2.14 fixture described in section 6.3. except red stopbar applications use a 32 watt MR-16 lamp.



Caution: Never handle the light assembly by the leads as this can break the waterproof seal

7 Installation

The ICAO TCL light units are shipped complete, including the lamp(s), and are ready for installation as received. Installation of a light unit is to be done with primary **POWER OFF** and **SECURED**. At each light location, install a 12-inch diameter, 12-inch deep minimum, light base. Consult FAA AC 150/5340-4 for installation procedures. Install the light base with two opposite boltholes perpendicular to the taxiway centerline. Place the properly sized isolation transformer(s) in the light base and make necessary primary power connections using L-823 connectors. Green and yellow units require either two 45 watt, 6.6A secondary transformers for the two lead version, or one 65 watt, 6.6A secondary transformer for the single lead version. Red(stopbar) units require a single 45 watt transformer for the C2 and W2 versions, a 65 watt transformer for N3 versions, and a 100 watt transformer for the C3 and W3 versions. Verify that the mounting flange on the light base is clean and the o-ring (optional on deep cans) is coated with Dow Corning FS 1292 grease and is in place on the light base. Connect the plug(s) from the light unit to the secondary(ies) of the previously installed isolation transformer(s). Installation tool, Crouse-Hinds P/N 19999, will ease in the installation and removal of the light unit (See Figure 1). The threaded eyebolts on the lifting tool screw into threaded holes in the light fixture. Lower the light unit straight down onto the base. The light fixture is subject to optical misalignment or mechanical damage if not seated properly. Verify the light beam(s)/color(s) are properly orientated for the individual location. Secure the light fixture to the base with six 3/8-16 UNC x 7/8 lg. stn. Stl. bolts and lockwashers and tighten to 225 +0 -10 in-lbs. (18 ft-lbs.). Loctite 242 may be used on the bolts to prevent loosening due to vibration.

8 Maintenance

The preferred method of maintaining these lights is to periodically and systematically replace the Optical Assembly and return it to the maintenance shop for renovation. As an alternative, the Optical Assembly can be serviced in the field. However, it is recommended that field servicing be limited to cleaning the lens as described in section 8.1 and to lamp replacements as described in section 8.2.

8.1 Cleaning Lenses

With a compressed air blast or suitable brushes, remove all accumulated debris from the light channel. Clean the outer surface of the prism with a detergent solution. If the lens is coated with a substance impervious to the detergent, a suitable solvent should be sparingly applied with a wad of cotton or a patch of cloth on the end of a wood splint. After the solvent has acted the remaining solvent and softened coating should be removed with a clean piece of cotton or cloth. Care should be taken to avoid excessive contact between the solvent and the lens seal. Remove all remaining solvent from lens and seal. A gentle air blast may be used.

Instruction Manual
Style 3
12 Inch ICAO Taxiway Centerline Light**8.2 Relamping**

Warning - Light assembly parts are hot when lamp is energized and remain hot for a short time after lamp/fixture is turned off.

Remove and secure power to the fixture. Separate the fixture from the base by removing the six bolts. Turn the fixture upside down and remove the six screws holding the inner cover to the optical housing. Disconnect the lamp leads from the feed-thru terminals. Remove the Lamp Assembly by gently pulling up on the lamp reflector base. Inspect the feed-thru terminal for signs of corrosion. Replace feed-thru assemblies per paragraph 8.5. Clean the inside surfaces of the lens(es) with denatured alcohol. Inspect the lamp holder bracket(s) for loose hardware; tighten the mounting screws to 30 in-lbs.



Caution – Touching the quartz bulb with bare fingers may seriously shorten lamp life. If the bulb has been touched, wipe it clean with a piece of lens cleaning tissue or similar material moistened with denatured alcohol.

Install the new lamp by reversing the procedure above. Make certain the rim of the reflector is flush against the bracket and seated against the two pins at the bottom of the bracket. Connect the lamp leads to the feed-thru terminals. Inspect/ replace the inner cover gasket per paragraph 8.3. Assemble the inner cover onto the light housing. The screw hole patterns in the inner cover and light housing are offset to insure proper alignment. Tighten the mounting screws to 30 in-lbs. Perform a pressure test as described in paragraph 8.6.

8.3 Gasket Replacement

Everytime the Optical Assembly is opened the gasket must be closely examined and replaced if necessary. Any gasket that is stretched, torn, has a permanent set or some other defect, which would prevent it from forming a watertight seal must be replaced with a new gasket.



Note – A bad gasket seal is the most common cause of inset fixture leaks. It is strongly recommended that a new gasket be installed every time the Optical Assembly is opened.

Remove the old gasket from the groove in the inner cover. Carefully clean the flange mating surfaces and the inner cover groove. This can be done by carefully scraping. Take care not to damage the mating surface and the bottom and sides of the groove. Coat the gasket (P/N 21140) with a thin layer of Dow Corning FS 1292 Lubricating grease. Position the new gasket in the center of the groove and press it into place. The grease will hold the gasket in place while the inner cover is positioned on the light housing. Torque the inner cover screws to 30 in-lbs. Perform a pressure test as described in paragraph 8.6.



Note – The groove is designed to be wider than the gasket. This provides room for displacement of the gasket when compressed between the housing and mating surface. Properly tightened screws are important in obtaining a complete seal.

8.4 Lens Replacement

If a lens is broken, leaks or is badly pitted or scarred, it must be replaced. It is highly recommended that this task be performed in a clean shop environment. Lens Replacement Kit P/N 21126-C contains all necessary

Instruction Manual
Style 3
12 Inch ICAO Taxiway Centerline Light

parts to change a lens. **Remove and secure power to the fixture.** Separate the fixture from the light base by removing the six bolts. Turn the fixture upside down and remove the six screws holding the inner cover to the optical housing. Remove the wedge filter and bracket assembly per paragraph 8.6. Remove the two mounting screws and filter bracket assembly from the optical housing. Remove the two lens retaining bracket screws from the optical housing. Remove the lens-retaining bracket and discard the lens-retaining gasket. Firmly push the lens/boot assembly from the outside of the optical housing; discard the old lens and boot. Thoroughly clean the lens opening with denatured alcohol and allow to dry. Inspect the lens opening for scratches or pits, a damaged lens opening surface will not seal properly. Place a new lens boot (P/N 21103) over the replacement lens (P/N 21102-C). Apply a thin coat of Dow Corning FS 1292 grease over the entire outside surface of the lens boot. Align the lens/boot assembly in the lens opening and press it into place. Verify that the lens boot is not pinched in the lens opening. Using a new lens retaining gasket (P/N 21101), fasten the lens retaining bracket (P/N 21100) to the light housing. Torque the mounting screws to 30 in-lbs. Assemble the filter bracket assembly onto the optical housing per paragraph 8.6. Assemble the inner cover onto the optical housing. The screw hole patterns in the inner cover and optical housing are offset to insure proper alignment. Torque the mounting screws to 30 in-lbs. Perform a pressure test per paragraph 8.7. Connect the fixture to the isolation transformer(s), and place the fixture on the light base. Verify the light beam(s)/color(s) are properly orientated for the individual location. Torque the mounting bolts to 225 in- lbs.

8.5 Feed-thru Replacement

Remove and secure power to the fixture. Separate the fixture from the light base by removing the six bolts. Turn the fixture upside down and remove the six screws holding the inner cover to the optical housing. Disconnect the lamp leads from the feed-thru terminals. Remove the feed-thru by unscrewing the retaining collar. Clean the mounting surface with Isopropyl Alcohol and allow to dry. Apply a thin coat of Dow Corning FS 1292 grease to the mounting flange of a new feed-thru (P/N 21121 for 2 lamp/ 1 plug, or P/N 21122 for 1 lamp/ 1 plug). Apply a drop of Loctite 242 to the feed-thru adapter threads. Screw the feed-thru retaining collar onto the adapter; refer to Figure 5 for proper inner cover/ feed-thru orientation. Torque the retaining collar to 30 in-lbs. Assemble the inner cover onto the optical housing. The screw hole patterns in the inner cover and light housing are offset to insure proper alignment. Torque the mounting screws to 30 in-lbs. Perform a pressure test per paragraph 8.7. Connect the fixture to the isolation transformer(s), and place the fixture on the light base. Verify the light beam(s)/color(s) are properly orientated for the individual location. Torque the mounting bolts to 225 in- lbs.

8.6 Fresnel Filter Replacement

The fresnel filter in the 852XX3 series fixtures determines the ICAO figure and color of the light beam. It can be replaced in the field. It is highly recommended that this task be performed in a clean shop environment. **Remove and secure power to the fixture.** Separate the fixture from the light base by removing the six bolts. Turn the fixture upside down and remove the six screws holding the inner cover to the optical housing. Note the orientation of the filter in the filter bracket assembly. The position of the filter in the bracket will affect photometric performance. Slide the filter out of the spring loaded bracket assembly. Place two new P/N 21132 wedge gaskets on the replacement filter mounting tabs, and slide the filter into position in the bracket.

Instruction Manual
Style 3
12 Inch ICAO Taxiway Centerline Light

Assemble the inner cover onto the light housing. The screw hole patterns in the inner cover and light housing are offset to insure proper alignment. Torque the mounting screws to 30 in-lbs. Perform a pressure test per paragraph 8.7. Place the Optical Assembly into the outer ring and torque the mounting bolts to 225 in-lbs.

8.7 Pressure Test

A light fixture should be subjected to a 20-psi air pressure test to verify that it is waterproof whenever it has been opened or components have been replaced. A tire valve style pressure fitting is located on the bottom of the inner cover. Pressurize the fixture to 20-psi then place it in a tub of water or use a soap solution to locate escaping air bubbles. Carefully inspect the areas around the lens, inner cover seal, and feed-thru adapter for leaks. Relieve the internal air pressure before installing the fixture or attempting to repair a leak.



Note – Do not exceed 20-psi when pressure testing the fixture. Serious injury and/or permanent damage to the fixture may result if a higher air pressure is used. Once the pressure test is complete be sure to relieve the air pressure.

8.8 Cleanliness and Workmanship

Service life depends upon the entire assembly being waterproof. All surfaces must be clean, dry and free of all foreign matter if the light fixture is to operate for extended periods without requiring maintenance.

8.9 Maintenance Program

In order to insure maximum light fixture life, the installed units should be subject to a maintenance program in accordance with the following:

A daily operation check should be made of the lighting fixture. The lights should be energized and visually inspected. If any lamps are out, the location of the fixture should be recorded and the lamps replaced at a time when the circuit is de-energized. (See Section 8.2)

- 8.9.1 Regular cleaning is necessary in order to insure that inset lighting fixtures operate at maximum efficiency. The lens and channel in front of the lens should be cleaned periodically with a soft cloth and solvent. The weather and the location of the fixtures will dictate the regularity and type of cleaning.
- 8.9.2 Snowplow operators should exercise extra care not to strike the light fixtures with snowplow blades. After snowplow removal operations, inspect all light fixtures to locate and replace if necessary, any damaged Light Assemblies. Passes over the light rows should be made with a power broom only if practical. Whenever snowplows must traverse in-pavement light fixtures, they should be traveling at less than 5 mph or have the blades lifted clear of the fixtures. Recommended snow removal techniques are described in AC 150/5200-23.
- 8.9.3 The light is designed to exclude both ground and surface water from entering. If the lights are not properly maintained (i.e., bolts tightened and seals in good condition) water may enter the fixture. To prevent this from occurring, it is recommended that each fixture be inspected for the presence of water at least once a month. More frequent inspection is desirable during and following rainy seasons.
- 8.9.4 Optical Assembly hold-down bolts should be checked for proper torque (225 +5, -0 in-lbs.) at least once every three months or whenever a fixture is serviced regardless of the season. Light fixtures in and around

**Instruction Manual
Style 3
12 Inch ICAO Taxiway Centerline Light**

the Touchdown Zone area are especially prone to vibration damage if the mounting bolts are not properly torqued. The mounting surface of the light base must be clean and free of foreign matter when checking mounting bolts.

- 8.9.5 If any fixture contains water, the water should be removed and the entire fixture cleaned and dried. Perform a pressure test per paragraph 8.7 to locate the source of the leak. Replace the bottom cover gasket, (P/N 21140), see Section 8.3.

Instruction Manual
Style 3
12 Inch ICAO Taxiway Centerline Light

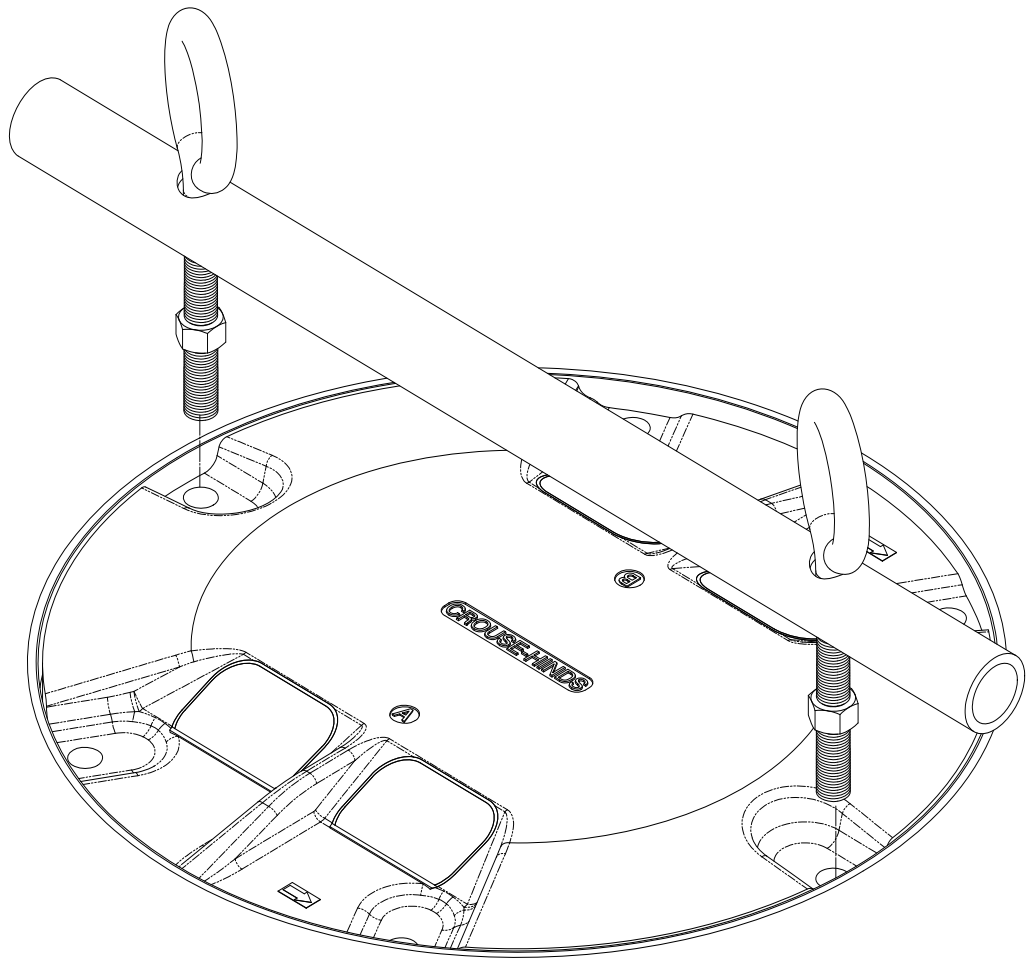

Figure 1 19999 Installation (Lifting) tool

Straight section optical housing shown

Instruction Manual
Style 3
12 Inch ICAO Taxiway Centerline Light

10 Parts List

	PART NUMBER	852W23 QTY	852W33 QTY	852N33 QTY	852C23 QTY	852C33 QTY	DESCRIPTION
1	21100	2	2	2	2	2	BRACKET, LENS RETAINING, 18-8 STN STL.
2	21101 *	1 or 2	1 or 2	1 or 2	1 or 2	1 or 2	GASKET, LENS RETAINING, BI-DIR. QTY = 2 UNI-DIR. QTY = 1
3	21102-C *	2	2	2	2	2	LENS, CLEAR
4	21103 *	2	2	2	2	2	BOOT, LENS
5	21210	0	0	0	1	1	OPTICAL HOUSING, MACHINED, CURVED SECTIONS
5	21137-2	1	1	1	0	0	OPTICAL HOUSING, MACHINED, STRAIGHT SECTIONS
6	21143	0 or 1	0 or 1	0 or 1	0 or 1	0 or 1	GASKET, BLANK COLOR, LENS RETAINING, BI-DIR. QTY = 0 UNI-DIR. QTY = 1
7	21109	0 or 1	0 or 1	0 or 1	0 or 1	0 or 1	FEED-THRU PLUG, ALUMINUM, BI-DIR. QTY = 0 UNI-DIR. QTY = 1
8	21140	1	1	1	1	1	GASKET, BOTTOM COVER
9	21226	1 or 2	0	1 or 2	1 or 2	1 or 2	LAMP BRACKET ASSEMBLY, 18-8 STN STL. BI-DIR. QTY = 2 UNI-DIR. QTY = 1
9	21461	0	1 or 2	0	0	0	LAMP BRACKET ASSEMBLY, 304 STN STL. BI-DIR. QTY = 2 UNI-DIR. QTY = 1
10	21127	1 or 2	1 or 2	1 or 2	1 or 2	1 or 2	LAMP/REFLECTOR ASSEMBLY, 32W, 6.6 A. BI-DIR. QTY = 2 UNI-DIR. QTY = 1
10	21116	1 or 2	1 or 2	1 or 2	1 or 2	1 or 2	LAMP/REFLECTOR ASSEMBLY, 48 W, 6.6A. BI-DIR. QTY = 2 UNI-DIR. QTY = 1
10	21169	0	0	1	0	0	LAMP/REFLECTOR ASSEMBLY, 62 W, 6.6A STOPBAR ONLY
10	21128	0	1	0	0	1	LAMP/REFLECTOR ASSEMBLY, 105W, 6.6A STOPBAR ONLY
11	21138-2	1	1	1	1	1	BOTTOM COVER, MACHINED, REL, ALUMINUM
12							
13	21120	1 or 2	1 or 2	1 or 2	1 or 2	1 or 2	ADAPTER, THREADED FEED - THRU, BI-DIR. QTY = 2 UNI-DIR. QTY = 1
14	21121	A/R	A/R	A/R	0	0	FEED-THRU ASSEMBLY P2 VERSION, QTY = 1
15	21122	A/R	A/R	A/R	1 or 2	1 or 2	FEED-THRU ASSEMBLY P1 VERSION, QTY = 1
16	10035-61	2	2	2	2	2	O-RING, FEED-THRU ADAPTER
17	10000-471	1	1	1	1	1	SCREW, SEMS, PAN HD TYPE 1A CROSS, GREEN, #10-32 X 3/8 LG, 18-8 STN STL.
18	10000-468	4	4	4	4	4	SCREW, SEMS, PAN HD TYPE 1A CROSS/DRI-LOC, #10-32 X 1/2 LG, 18-8 STN STL.
19	10000-469	8 or 16	8 or 16	8 or 16	8 or 16	8 or 16	SCREW, SEMS, PAN HD TYPE 1A CROSS/DRI-LOC, #8-32 X 3/8 LG, 18-8 STN STL. BI-DIR. QTY = 10 UNI-DIR. QTY = 5
20	10000-400	6	6	6	6	6	SCREW, HEX WASHER HEAD/DRI-LOC, #10-32 X 3/8 LG, 18-8 STN STL.
21	21211	0	0	0	1	1	BRACKET, LAMP MOUNTING, CURVED SECTIONS
21	21148	1 or 2	1 or 2	1 or 2	0	0	BRACKET, LAMP MOUNTING, BI-DIR. QTY = 2 UNI-DIR. QTY = 1
22	21129	1 or 2	1 or 2	1 or 2	1 or 2	1 or 2	BRACKET, WEDGE FILTER, BI-DIR. QTY = 2 UNI-DIR. QTY = 1
23	21131	1 or 2	1 or 2	1 or 2	1 or 2	1 or 2	SPRING CLIP, WEDGE BRACKET, BI-DIR. QTY = 2 UNI-DIR. QTY = 1
24	21132	2 or 4	2 or 4	2 or 4	2 or 4	2 or 4	GASKET, WEDGE FILTER, BI-DIR. QTY = 2 UNI-DIR. QTY = 1
25	21179-Y	A/R	A/R	0	A/R	A/R	FRESNEL FILTER, AVIATION YELLOW
26	21179-G	A/R	A/R	0	A/R	A/R	FRESNEL FILTER, AVIATION GREEN
27	21179-R	A/R	A/R	0	A/R	A/R	FRESNEL FILTER, AVIATION RED
28	21228-Y	0	0	A/R	0	0	FRESNEL WEDGE WITH BAFFLE, AVIATION YELLOW
29	21228-G	0	0	A/R	0	0	FRESNEL WEDGE WITH BAFFLE, AVIATION GREEN
30	21228-R	0	0	A/R	0	0	FRESNEL WEDGE WITH BAFFLE, AVIATION RED
31	10037-795	1	1	1	1	1	FITTING, PRESSURE TEST, 1/8-NPT
32	10048-25 *	A/R	A/R	A/R	A/R	A/R	SILICONE GREASE
33	10048-106	A/R	A/R	A/R	A/R	A/R	PIPE SEALANT PASTE
34	21152	0	0	0	A/R	A/R	TERMINAL, DUAL MALE FAST-ON
35	21154	0	0	0	0 or 2	0 or 2	JUMPER, LAMP BI-DIR. QTY = 2 UNI-DIR. QTY = 0

* These parts are included in a P/N 21126-C Lens Replacement Kit. Each kit contains parts to replace one lens.

Instruction Manual
Style 3
12 Inch ICAO Taxiway Centerline Light

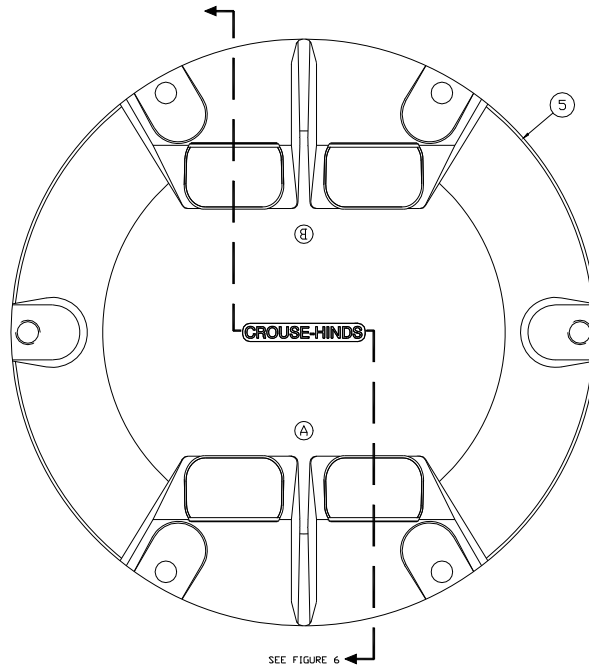

**Figure 2 Top View of Fixture
(straight section optical housing shown)**

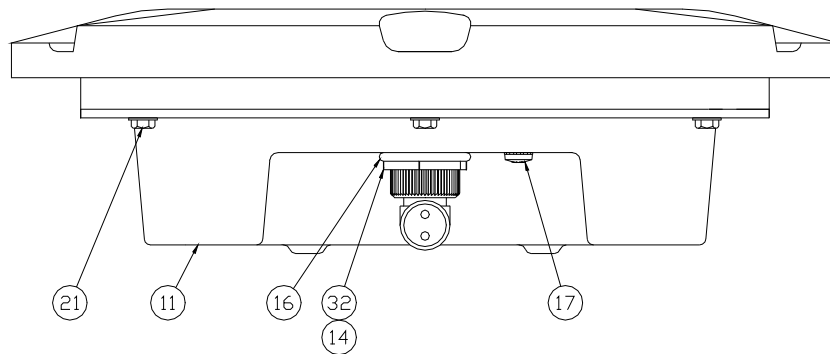

Figure 3 Side View of Fixture

Instruction Manual
Style 3
12 Inch ICAO Taxiway Centerline Light

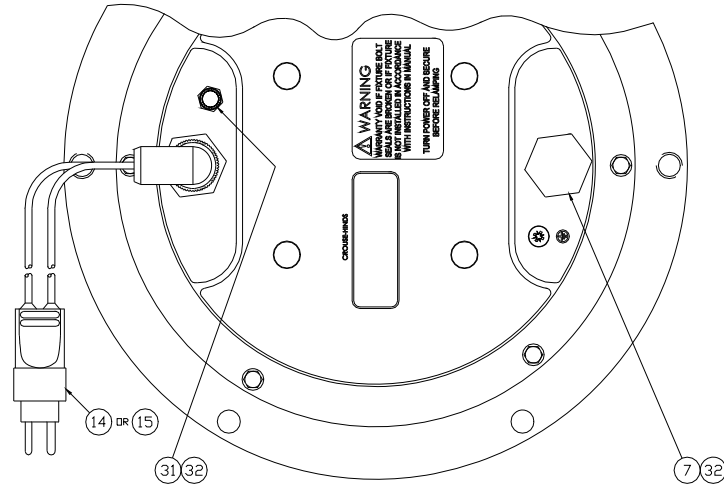

Figure 4 Bottom View of Fixture

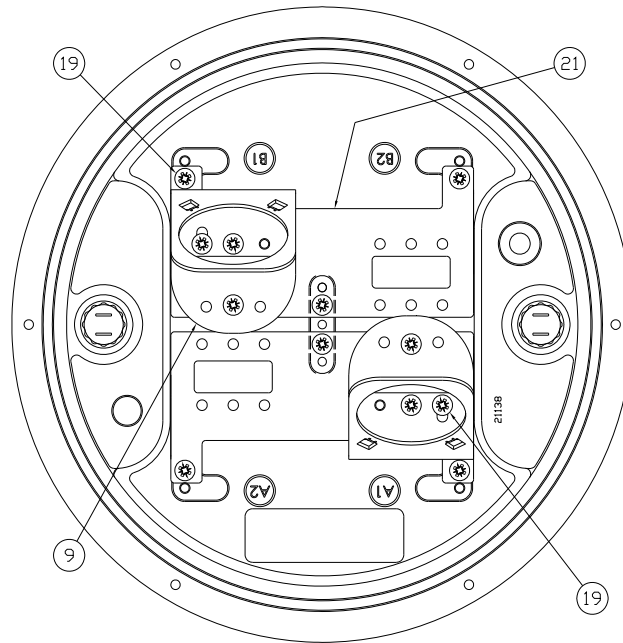

Figure 5 Inner Cover Lamp Bracket Positioning
(straight section inner cover shown)

Instruction Manual
Style 3
12 Inch ICAO Taxiway Centerline Light

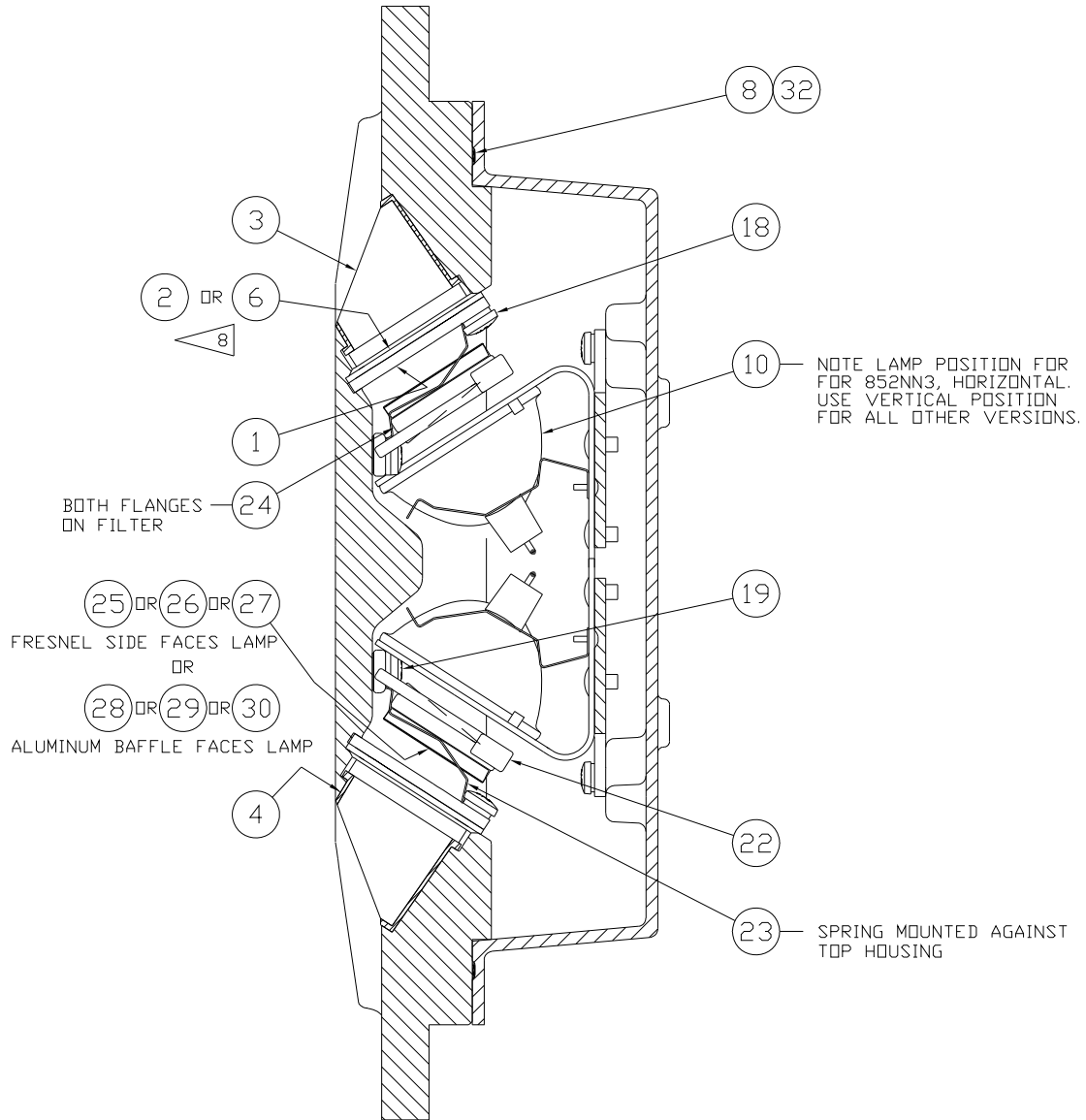

Figure 6 Cut Away View of Fixture